

User Manual

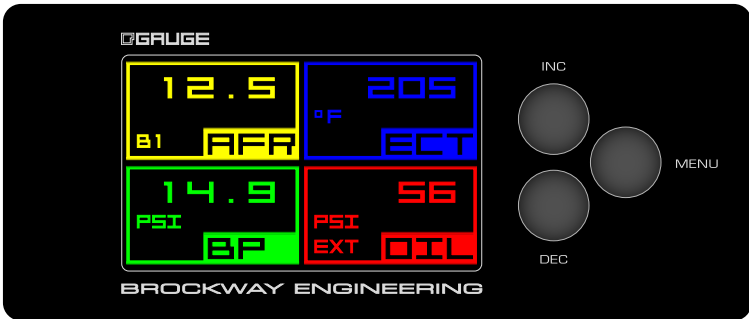

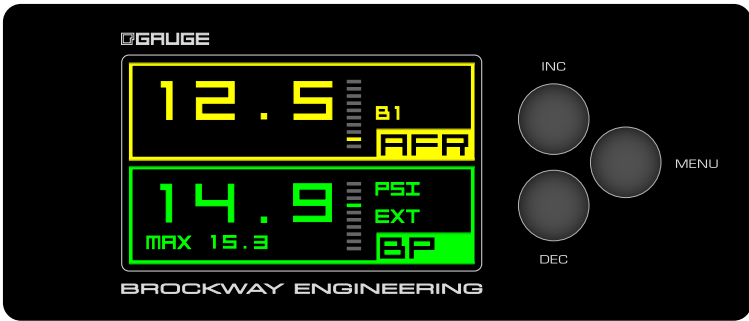

*Mounting Hole depth is 0.2". DO NOT exceed this depth with mounting screws.
*Mounting screws are #4 self threading type.

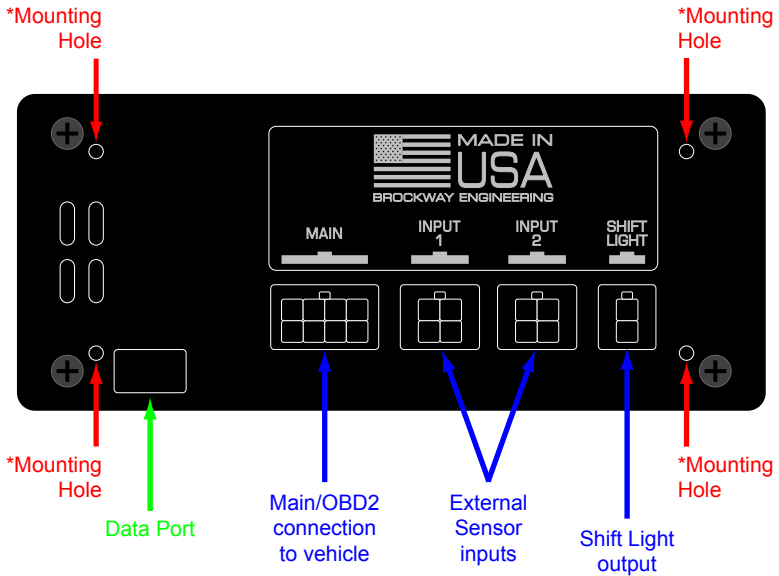

Digital OBD2 Gauge

The DGauge is a digital multi-gauge that plugs into the diagnostic port on most 1996 and later Asian, European and some US vehicles and displays real-time engine data on it's color TFT LCD. The data is communicated from the vehicle ECU to the DGauge and accuracy is ensured by the OBD2 protocol. Through the selection of one of 3 different screen modes, you can monitor 2 or 4 user selectable parameters at a time. As many as 25 different parameters are available for viewing, depending on vehicle support, and 7 parameters via external sensors.

Getting Started

The DGauge does not have a power switch. It automatically turns on upon successfully communicating with the vehicle and turns off when the communication stops. There is generally no OBD communication unless the vehicle ignition is turned on. Each time the DGauge turns on, it requests a list of supported parameters, known as PIDs. The DGauge uses this list to determine what is available and prevent you from selecting a parameter that is not supported. A complete list of parameters that the DGauge is capable of displaying can be found in appendix A.

The DGauge display is arranged as 2 sets of 2 gauges and 1 set of 4 gauges. Each set is referred to as a "screen". To switch from one screen to another, press the INC button to increment to the next screen or the DEC button to decrement to the previous screen. Screen 1 displays gauges 1 and 2. Screen 2 displays gauges 3 and 4. Screen 3 displays all 4 gauges. To enter the setup menu, press the MENU button. Setup options are arranged in sequence, stepping through each option by pressing the MENU button, much like turning a page in a book, and finally exiting the setup menu. You can also exit the setup menu at any point by pressing and holding the MENU button for approximately 1 second.



Installation

Locate the diagnostic connector in the vehicle. It is usually under the dash on the driver's side. It is a 16 pin connector that is usually exposed, but sometimes it is hidden behind a small door.

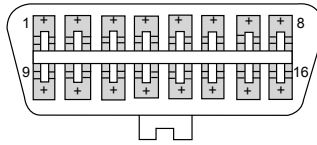

Connect the mating end of the included data link cable to this connector and the other end to the DGauge MAIN connector.

The DGauge should power up and try to communicate with the vehicle. If unsuccessful, it will power down and go to sleep. If it successfully communicates with the vehicle, then it will initialize and begin displaying realtime engine data.



Gauge Parameters

For each of the 4 gauges, you can select any available parameter. To select a parameter, press the MENU button to enter the setup menu. The first option is for selecting the gauge parameters for 1 and 2. The second option is for selecting the gauge parameters for 3 and 4.

SCREEN 1

GAUGE 1 RPM

GAUGE 2 O2 B1

SCREEN 2

GAUGE 3 EXT

GAUGE 4 VSS

To select the parameter for gauge 1, press the INC button to scroll through available parameters. Repeat for gauge 2 using the DEC button. Repeat this procedure for screen 2 (gauges 3 and 4).

For some OBD parameters, the tag will include a "B1" for cylinder bank 1 or a "B2" for cylinder bank 2. In some cases you may see B1 and B2 listed for a single cylinder bank, such as a straight six. For external sensors, you will see an "EXT" after the parameter tag. Vehicles equipped with standard narrow band O2 sensors will report the sensor voltage and vehicles equipped with wideband O2 sensors will report AFR (A/F ratio, which is actually converted from lambda).



External Sensors

The DGauge has 2 inputs for connecting external sensors. To select an external sensor connected to input 1, press the INC button to scroll through available sensor types. Repeat for input 2 using the DEC button. The same sensor type cannot be selected for both inputs. Available external sensor types are AFR, BP, OIL, FRP, EGT, EOT and IAT. See appendix B for external sensor details.

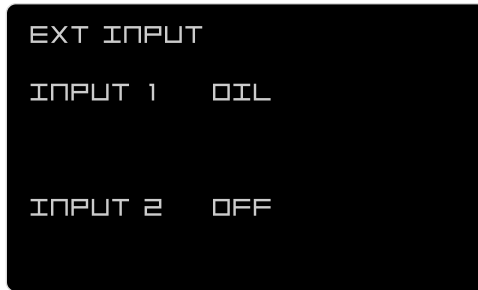

If BP is selected for one of the inputs, then you have the option to select the BP sensor type on the next setup screen. To select a BP sensor type, press the button next to the hot key label of choice. The 50 psi sensor is good for boost pressure up to 35 psi and the 75 psi sensor is good for boost pressure up to 60 psi.





Gauge Color

The DGauge has 12 colors to choose from for each gauge. To select a color for gauge 1, press the INC button to scroll through available colors. Repeat for gauge 2 using the DEC button. Repeat above procedure for gauges 3 and 4. Color choices are red, orange, amber, yellow, green, ocean, aqua, blue, purple, pink, white and gray.



Units

The DGauge can display English or Metric units for temperature (°F or °C) and vehicle speed (MPH or KMH). To select a unit of measure, press the button next to the hot key label of choice. ENG = English, MET = Metric.

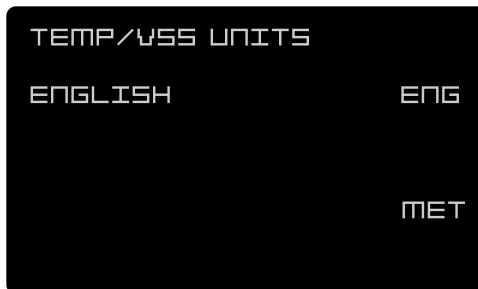



Pressure Units

The DGauge can display English or Metric units for pressure. The options are PSI (pounds/square inch) and KPA (kilopascal). This setting will affect BP, OIL and FRP parameters. To select the unit of measure, press the button next to the hot key label of choice.



MAP/Boost Auto Calibration

The DGauge has an auto calibration feature for accurately reading boost from the factory MAP sensor. To perform the auto calibration you must turn the ignition on without starting the engine. Wait for the DGauge to initialize, then start the engine. This only has to be done once after connecting the DGauge but again if you unplug it. You may also want to re-calibrate if you change elevation by more than 500 feet. During auto calibration, the DGauge reads the MAP sensor to get the ambient pressure and stores it. This is used as the base value to determine boost. Any manifold pressure that exceeds the base value is considered boost. If the auto calibration is not performed, then the DGauge will use the default value of 101 kPa, which is the ambient pressure at sea level.



Alerts

The DGauge has an alert function for ECT, EOT, EGT, OIL and BP. The associated alert will not appear in the setup menu unless the parameter is selected for one of the gauges. To adjust an alert set point, press the INC button to increase and the DEC button to decrease the set point value. An alert becomes active when the parameter value exceeds the set point, with the exception of OIL, in which case the alert becomes active when the pressure drops below the set point. When an alert is active, the parameter value displayed will blink.

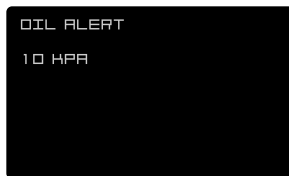
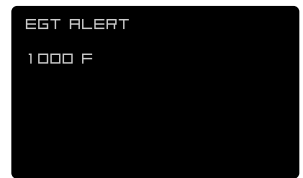
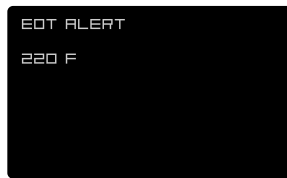

The DGauge will continue to monitor EOT and OIL external parameters in the background if one or both of them are selected as an external input. Using the same set point value as the display alert, the DGauge will activate the external alert. Use the EA1 wiring kit to connect an external alert.



Shift Light RPM

The shift light output is controlled by the shift light RPM setting. The output is turned on whenever the engine RPM exceeds the set point. To adjust the set point, press the INC button to increase the set point and the DEC button to decrease the set point. The setting range is 3000 to 9900 in 100 RPM increments. This feature must have engine RPM data in order to function. You can either select RPM as an active gauge parameter or turn on RPM Tracking.



RPM Tracking

To turn on RPM tracking, press the button next to the hot key labeled ON and turn off by pressing the button next to the hot key labeled OFF.





Gear Position

The Gear Position indicator is controlled by a set point for each gear. The DGauge calculates the ratio from RPM and vehicle speed. Start with gear 1. While the vehicle is in 1st gear, very lightly accelerate. During this very light acceleration, press the SET button. The current ratio will be stored and the GR position will change to read "SET" and the text will be green. Do not push in the clutch during this procedure as it will effectively change the ratio. Proceed to gear 2 and repeat above procedure. If 6th gear is not used, then leave it unset. If you accidentally set it, then press the SET button with the vehicle stopped and the engine at idle RPM.

Any time the DGauge cannot identify a gear, it will display "0".



GEAR 1 SET

GR 1



GEAR 1 SET

SET



LCD Backlight

The LCD backlight brightness can be adjusted from 10% to 100% in 10% increments. Press the INC button to increase and the DEC button to decrease.

A black rectangular LCD display with white text. The text is arranged in two lines: 'LCD BACKLIGHT' on the top line and '100%' on the bottom line.

LCD BACKLIGHT

100%



Power On Mode

The DGauge has 2 Power On modes, Auto and Manual. Press the AUTO hot key to select Auto mode and press the MANUAL hot key to select Manual mode. In the Auto mode, the DGauge will continuously repeat a cycle of sleep for 7 seconds and then wake up and attempt communication with the vehicle ECU. If communication fails, then it will go back to sleep. In Manual mode, the DGauge will simply sleep until you press the MENU button. In both modes, the DGauge will still automatically go to sleep when the ignition is turned off. The Power On mode only affects how the DGauge powers on. During sleep mode the DGauge draws about 650uA of current. During normal operation (anytime the DGauge is awake) the DGauge draws about 130mA.

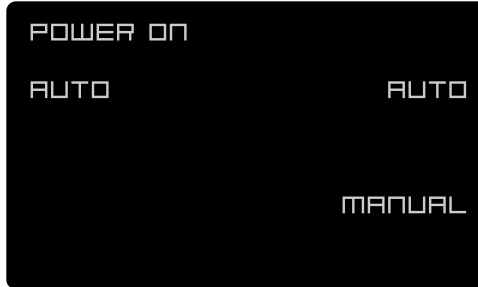



Diagnostic Trouble Code (DTC) Display

The DGauge can read (scan) and clear diagnostic trouble codes. Upon entering this setup screen, the DGauge automatically scans once for codes and displays the number of codes found. You may also press the button next to the SCAN hot key label.



If there are stored codes, then a list of the codes will be displayed. You will also have the option to clear them by pressing the button next to the CLEAR hot key label. The DGauge will only display a maximum of 5 codes.

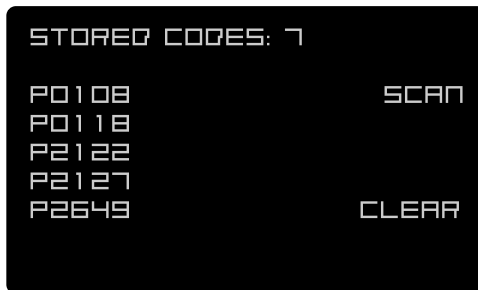



Appendix A

Parameter acronyms.

IGN - Ignition Timing Advance

RPM - Revolutions Per Minute

TPS - Throttle Position Sensor

IAT - Intake Air Temperature (OBD and EXT)

AAT - Ambient Air Temperature

ECT - Engine Coolant Temperature

EOT - Engine Oil Temperature (OBD and EXT)

VSS - Vehicle Speed Sensor

STF - Short Term Fuel Trim

LTF - Long Term Fuel Trim

CLV - Calculated Load Value

ALV - Absolute Load Value

MAP - Manifold Absolute Pressure

MAF - Mass Air Flow

O2 - Oxygen Sensor

AFR - Air/Fuel Ratio (OBD and EXT)

ALC - Fuel Alcohol Percentage (only seen on Flex Fuel vehicles)

BAT - Battery Voltage

FRP - Fuel Rail Pressure (OBD and EXT)

BP - Boost Pressure (OBD and EXT)

OIL - Oil Pressure (EXT only)

EGT - Exhaust Gas Temperature (EXT only)

GR - Gear Position



Appendix B

External Sensors.

To use an external sensor, you must purchase a connection cable and the sensor. Both are sold separately. The connection cables are manufactured by Brockway Engineering and the sensors are manufactured by AEM Electronics.

AFR - Air/Fuel Ratio. Use connection cable WM4 and AEM inline wideband sensor 30-2310.

BP - Boost Pressure. Use connection cable D3M4A and AEM pressure sensor 30-2131-50 (up to 35psi of boost) or 30-2131-75 (up to 60psi of boost).

OIL - Oil Pressure. Use connection cable D3M4A and AEM pressure sensor 30-2131-100.

FRP - Fuel Rail Pressure. Use connection cable D3M4A and AEM pressure sensor 30-2131-100.

EGT - Exhaust Gas Temperature. Use connection cable EGT2 and AEM sensor 30-2067.

EOT - Engine Oil Temperature. Use connection cable D2M4C and AEM sensor 30-2012.

IAT - Intake Air Temperature. Use connection cable D2M4A and AEM sensor 30-2010.



Appendix C

Accessories.

Accessories are sold separately.

SL2A - LED Shift Light with lens.

D2M4A - Connection cable for external IAT sensor.

D2M4C - Connection cable for external EOT sensor.

D3M4A - Connection cable for external pressure sensors.

EGT2 - Connection cable for external EGT sensor.

WM4 - Connection cable for external A/F ratio sensor.

EA1 - Wiring kit for external alert.



Warranty

Brockway Engineering, LLC hereby warrants that this product will be free of defects in materials and workmanship for a period of 1 year after date of purchase. At it's option, Brockway Engineering, LLC will repair or replace the defective product.